

MicroDim Dual P/N 9100-001-J

Rev SWP (Short Wing Piper)

Installation and Operating Instructions

PARTS SUPPLIED 9100-001-J:

- 1 ea MicroDim Control P/N 9100-001-J, Rev. SWP, Installation manual
- 4 ea Fully Insulated Blue Female #6 Crimp on Ring Lug Connectors for 14-16 AWG Wire.
- 4 ea 6-32 X 1/4 Button Head Socket SS screws including #6 SS Internal Lock Washer
- 1 ea 1/16 in Long Handle Key Allen Wrench
- 1 ea 5/64 in Long Handle Key Allen Wrench
- 1 ea Knob, various mounting hardware, 2 placards,

CAUTION- REVERSE WIRING OF POWER TO DEVICE WILL DAMAGE IT.

NEW INSTALLATION:

1. Locate a convenient place for the MicroDim Control. Drill a 9MM hole at the location where the center of the MicroDim is desired.
2. Determine the current that the circuit will be required to carry.
3. Test Position of MicroDim Control and determine if any additional wire is required.
4. Remove the MicroDim Control and proceed with the installation. From the **WIRE SIZE-CURRENT CAPACITY TABLE**, select the wire size required. If the installation is in an Aircraft, use only MIL-W-16878E/4 Type E, Teflon insulated, Silver-Plated Copper Wire or equivalent.
5. Find the location of the power source.
6. Install a breaker of 'Calculated Size', see Wiring Diagram for sizing.
7. Run a wire from the Breaker to the MicroDim controller positive (POS) terminal, then Select and crimp Blue Female Solderless Ring Lug Connector on the end of the wire. Attach the ring connector onto the positive connector on the MicroDim controller using a washer and a SS screw .
8. Using the same technique that was used in section #7, run a wire from the GND ring terminal on the MicroDim to system ground. The common (Gnd) Wire is simply a signal wire used by the unit. It does not carry heavy currents during operation. Use a Blue Female Solderless Ring Lug Connector for this wire.
9. Again using the same technique that was used in section #7, run a wire from the output CKT on the dimming circuit. Select and crimp on a Blue Crimp on ring Connector the end of the wire. Attach the ring connector onto the connection the Micro Dimmer controller using a washer and a Button Head Socket SS screw.
10. Having installed the label over the 9mm drilled hole using the label installation instructions, then insert the MicroDim Control from the rear into the drilled hole and install a washer and the nut to hold the MicroDim control in place and tighten the nut.
11. Install the knob using the Long Handle Key Allen Wrench provided.

EXISTING/REPLACEMENT INSTALLATION:

1. Locate a convenient place for the MicroDim Control. Drill a 9MM hole at the location where the center of the MicroDim is desired. Determine the Positive supply, MicroDim circuit, and negative ground wiring.
2. Test Position the MicroDim Control and determine if any additional wire is required for the installation.
3. Insure that a breaker for the MicroDim Controller power source is installed in series with power source and sized to 'Calculated Value' as defined on the wiring diagram.

Document 9150-016-A

4. Remove the MicroDim Control and proceed with the installation. From the wire size-current capacity table, select the wire size required if additional wire is required. If the installation is in an Aircraft, use only MIL-W-16878E/4 Type E, Teflon insulated, or equivalent Silver-Plated Copper Wire.
5. Run a wire from the Breaker to the MicroDim controller positive (POS) terminal, then Select and install a Blue Female Solderless Ring Lug Connector on the end of the wire. Attach this to the POS connector on the MicroDim controller.
6. Using the same technique that was used in #5, run a wire from the male connector terminal on the MicroDim to system ground. The common (Gnd) wire is simply a signal wire used by the unit. It does not carry heavy currents during operation. Use a Blue Solderless Ring Lug Connector for this wire. Connect to GND connector of device.
7. Again using the same technique that was used in #5, run wire from output CKT for the dimming circuit. Select and install a Blue Solderless Ring Lug Connector on the end of the wire and connect it onto the male connector on the MaxDim Controller.
8. With the MicroDim Control inserted from the rear into the 9MM drilled hole and with the reference label placed over the threads on the MicroDim Control, install a washer and a nut to hold the MicroDim Control in place.
9. Install the knob using the 1/16" long handle key Allen wrench provided.

FUNCTIONAL TEST:

1. Turn the knob fully counter clockwise and apply power to the system.
2. Slowly rotate the knob clockwise. The CKT1 will activate and with a continued clockwise rotation the lights will increase in intensity.
3. Fully Clockwise rotation applies the full voltage to the Lights MicroDim Circuit (CKT1).
4. Fully Counterclockwise removes the voltage from the Lights MicroDim Circuit (CKT1).
5. CKT2 of the Micro Dimmer will be at full voltage when there is an output on CKT1.
6. The Light MicroDim Circuit voltage is continuously variable from off to full on.

Wiring Diagram 9100-001-J MicroDim SWP

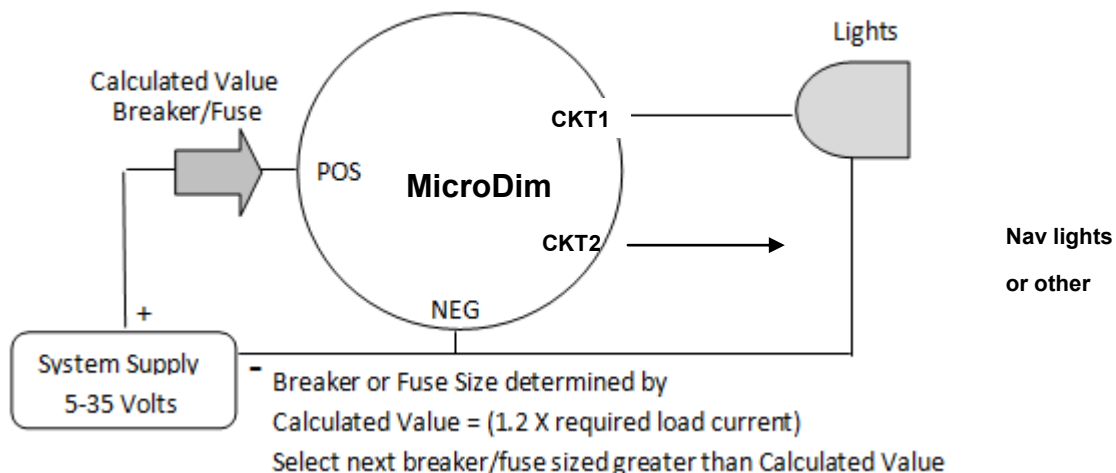

—SPECIFICATIONS—

Voltage Range: 5 to 35VDC

Max Current: 7.5 A

Controlled Output: 0 to 5/35 VDC

0 to 7.5A

Capacity:

- 38 Watts @ 5 VDC
- 90Watts @12 VDC
- 180 Watts @ 24 VDC
- 210 Watts @ 28 VDC

Operating Temperature range: -30°C to +65°C

Internal Temperature Protect: +85°C

Storage Temperature: -40°C to +100°C

Maximum Internal Temperature: @ 7.5A
+5 °C above Ambient.

Enclosure Material: Bayer FR 110 Resin

Meets UL 94 Flame Rating: V-2 (0.03in) V-0
(0.059in) 5VB (0.098in) 5VA (0.13in)



Approvals: DO-160E, Emissions

Potentiometer Rotation: 270 Deg.

Order P/N 9100-001-J

Rotational Life: 500KTurns

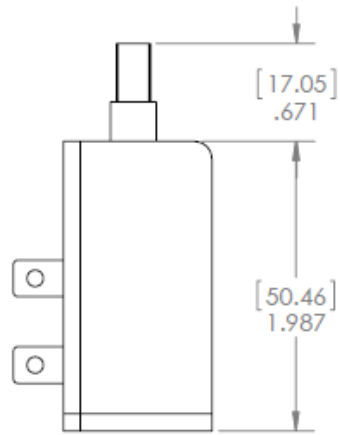
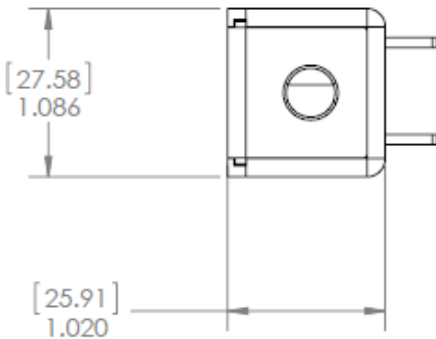

ONE YEAR LIMITED WARRANTY

MPMD will repair or replace, at its expense and at its option any device manufactured by MPMD which in the normal use has proven to be defective in workmanship or material, provided that the customer returns the product prepaid to MPMD along with proof of purchase of the product within one year and provides MPMD with reasonable opportunity to verify the alleged defect by inspection. MPMD will not be responsible for any asserted defect which has resulted from misuse, abuse or over stressing above the published specifications. MPMD will under no circumstances be liable for incidental or consequential damages resulting from the defective products. This warranty is MPMD's Sole warranty and sets forth the customer's exclusive remedy, with respect to defective products; all other warranties, express or implied, whether of merchantability, fitness for purpose, or otherwise, are expressly disclaimed by MPMD.

MaxPulseMaxDim.com, Statesboro, GA

912-489-0094

CAUTION

Most EFIS, GPS, etc. equipment with screens have their own internal dimming control circuitry and only the steam gauge instruments and panel incandescent or LED lights are controlled by the independent Micro Dimmer controller. However, the installing technician and the owner must perform a post installation check for proper function and verification of compatibility with any existing equipment that might appear on these airplanes. With the possibility that there might be Electronic Flight Instrument Systems (EFIS) tied into the existing Micro Dimmer circuitry, the FAA has advised that the installing Technician and owner verify that they cannot dim any (EFIS) all the way to zero, so there is no danger of failure of this simple MaxDim Micro causing all the (EFIS) displays/instruments to be black. If this incompatibility exists the (EFIS) must be removed from the dimming circuit.

FAA REQUIREMENTS

Amend the weight and balance records and make the necessary log book entry. Complete an FAA form 337 showing the installation of this equipment in accordance with the STC instruction and submit one copy to the FAA and one copy to the aircraft owner. File all data and a copy of the STC with the aircraft records.

INSTRUCTIONS FOR CONTINUED AIRWORTHINESS

The Airworthiness Limitations section is FAA approved and specifies maintenance required under Part 43.16 and 91.403 of the FAR's unless an alternative program has been FAA approved. **Airworthiness Limitation:** Micro Dimmer Light Controller P/N 9100-001-J, manufactured by MPMD has no repairable parts.

General Engineering Data Regarding Wire Sizes and Current Capacities Capacity Data
WIRE AND CABLE DERATING CRITERIA FROM MIL-STD-975

AWG	Diameter	Diameter	Ohms Per	Ohms Per	Maximum	AWG	Derated Current	
Gauge	Inches	mm	1000 Ft	km	Ampere	Gauge	Single	Bundled
14	0.0641	1.6281	2.525	8.282	32	14	19.0	8.5
15	0.0571	1.4503	3.184	10.4435	28	15	16.6	7.4
16	0.0508	1.2903	4.016	13.1725	22	16	13.0	6.5
17	0.0453	1.1506	5.064	16.6099	19	17	11.2	5.6
18	0.0403	1.0236	6.385	20.9428	16	18	9.2	5.0
19	0.0359	0.9119	8.051	26.4073	14	19	8.1	4.4
20	0.032	0.8128	10.15	33.292	11	20	6.5	3.7
21	0.0285	0.7239	12.8	41.984	9	21	5.3	3.0
22	0.0254	0.6452	16.14	52.9392	7	22	4.5	2.5